

# PowerHawk 6103, 6203 and 6303 meters

## High Density Meters

Installation Guide



## Hazard Categories and Special Symbols



Read these instructions carefully and look at the equipment to become familiar with the device before trying to install, operate, service or maintain it. The following special messages may appear throughout this bulletin or on the equipment to warn of potential hazards or to call attention to information that clarifies or simplifies a procedure.

The addition of either symbol to a “Danger” or “Warning” safety label indicates that an electrical hazard exists which will result in personal injury if the instructions are not followed.

This is the safety alert symbol. It is used to alert you to potential personal injury hazards. Obey all safety messages that follow this symbol to avoid possible injury or death.

### **⚠ DANGER**

**DANGER** indicates an imminently hazardous situation which, if not avoided, **will result in** death or serious injury.

### **⚠ WARNING**

**WARNING** indicates a potentially hazardous situation which, if not avoided, **can result in** death or serious injury.

### **⚠ CAUTION**

**CAUTION** indicates a potentially hazardous situation which, if not avoided, **can result in** minor or moderate injury.

### **CAUTION**

**CAUTION**, used without the safety alert symbol, indicates a potentially hazardous situation which, if not avoided, **can result in** property damage.

**NOTE:** Provides additional information to clarify or simplify a procedure.

#### PLEASE NOTE

Electrical equipment should be installed, operated, serviced, and maintained only by qualified personnel. No responsibility is assumed by Triacta for any consequences arising out of the use of this material.

#### FCC NOTICE

This equipment has been tested and found to comply with the limits for a Class B digital device, pursuant to part 15 of the FCC Rules. These limits are designed to provide reasonable protection against harmful interference when the equipment is operated in a commercial environment. This equipment generates, uses, and can radiate radio frequency energy and, if not installed and used in accordance with the instruction manual, may cause harmful interference to radio communications. Operation of this equipment in a residential area is likely to cause harmful interference in which case the user will be required to correct the interference at his own expense. This Class B digital apparatus complies with Canadian ICES-003.

**INDUSTRY CANADA CLASS B EMISSION  
COMPLIANCE STATEMENT**

This equipment does not exceed the Class B limits for radio noise emissions from digital apparatus as set out in the radio interference regulations of the Canadian ICES-003.

Avis de conformité aux normes d'Industrie Canada. Cet appareil numérique de la classe B est conforme à la norme NMB-003 du Canada.

**UL**

UL (Underwriters Laboratories) are listed by the American Federal Occupational Safety and Health Administration (OSHA) under NRTL (Nationally Recognized Testing Laboratory) program. They are also accredited by Standards Council of Canada. This equipment complies with UL 61010-1 Second Edition and CSA C22.2 No. 61010-1-04.



# Table of Contents

|  |           |
|--|-----------|
| <b>INTRODUCTION .....</b>  | <b>1</b>  |
| System Description .....   | 1         |
| PowerHawk 6203 and 6303 System Specifications .....                                  | 1         |
| <b>SAFETY PRECAUTIONS.....</b>   | <b>5</b>  |
| Electrical Safety Compliance .....   | 5         |
| <b>INSTALLATION.....</b>   | <b>6</b>  |
| Pre-Installation .....   | 6         |
| Receiving .....  | 6         |
| Pre-Installation Checklist .....   | 6         |
| Site Planning .....  | 6         |
| Installation Procedures .....  | 7         |
| Mounting the PowerHawk Meters .....  | 8         |
| Installing Potential Transformers for Three-Phase Service Greater Than<br>277V ..... | 10        |
| Installing the Current Transformers .....  | 20        |
| Connecting the Communications .....  | 25        |
| Start-Up Sequence .....  | 25        |
| Pulse Inputs .....   | 26        |
| Display Navigation .....   | 26        |
| Completing the Installation Record .....   | 27        |
| <b>MAINTENANCE .....</b>   | <b>29</b> |
| Fuse Replacement .....   | 29        |
| <b>REGULATORY COMPLIANCE.....</b>  | <b>30</b> |
| Equipment servicing and access .....   | 30        |
| <b>USER NOTES.....</b>   | <b>35</b> |



## INTRODUCTION

This document describes the PowerHawk 6203 and 6303 meters, including procedures to install and start up the unit, and complete the initial configuration:

- “System Description” on page 1
- “Pre-Installation” on page 6
- “Installation Procedures” on page 7
- “Start-Up Sequence” on page 25
- “Fuse Replacement” on page 29

This documentation is intended for those responsible for installing and configuring the PowerHawk 6203 and 6303 meters. Installers must be qualified electricians with knowledge of local and national code requirements. See “Safety Precautions” on page 5.

## System Description

The PowerHawk 6203 and 6303 meters support:

- single-phase, 2-wire
- single-phase, 3-wire (network)
- three-phase wye and Delta services

Depending on how the meters are installed and configured, they can meter 2, 3, or 6 individual meter points. The PowerHawk 6203 and 6303 meters are designed for residential, commercial, and industrial use and display the power and consumption readings for each measurement point.

## PowerHawk 6203 and 6303 System Specifications

The PowerHawk 6203 and 6303 system architecture includes:

- single-phase, 2-wire; single-phase, 3-wire (network); and three-phase compatibility
- 120/208V, 120/240V and 277/480V configurations, and 347/600V with external potential transformers
- up to 2, 3, or 6 individual meter points
- local Ethernet configuration interface via PC and web browser
- on-board modem and Ethernet ports for remote reporting
- serial port for remote display
- 2 pulse inputs to connect metering devices

Table 1 lists the system specifications of the PowerHawk 6203 and 6303 meters.

**Table 1: PowerHawk 6203 and 6303 meter specifications**

| Specification  | PowerHawk 6203 meter  | PowerHawk 6303 meter  |
|--|---|---|
| Dimensions   | Height: 13.125 in. (33.5 cm)<br>Width: 12 in. (30.5 cm)<br>Depth: 2.125 in. (5.5 cm)                  | Height: 13.125 in. (33.5 cm)<br>Width: 12 in. (30.5 cm)<br>Depth: 2.125 in. (5.5 cm)  |
| Weight   | 8.77 lb (3.98 kg)   | 8.77 lb (3.98 kg)   |
| Sense voltage  | 100V to 300V 50/60Hz<br>2W+N+Protective Earth Wye 3W+N+Protective Earth Wye 3W+Protective Earth Delta | 100V to 300V 50/60Hz<br>2W+N+Protective Earth Wye 3W+N+Protective Earth Wye 3W+Protective Earth Delta   |
| Control voltage and current  | North America: 120V 125 mA 60 Hz<br>International: 230-240V 63 mA 50/60 Hz                            | North America: 120V 125 mA 60 Hz<br>International: 230-240V 63 mA 50/60 Hz  |
| Current transformers<br>Measurement Category III                     | 0.333 V secondary CT<br>Note: All CTs used with the product must be UL recognized/listed.             | 80 mA secondary CT<br>200 A primary CT<br>Meter burden: 4.04 ohms<br>CT burden: 20 ohms<br>Triacta part number 900-313-00 Model 7896<br>Note: All CTs used with the product must be UL recognized/listed. |
| Measurement accuracy<br>(Accuracy compliant when used with 0.3% CTs) | ANSI C12.20 Class 0.5<br>IEC 62053-22 Class 0.5S  | ANSI C12.20 Class 0.5<br>IEC 62053-22 Class 0.5S<br>Measurement Canada Approved<br>EG07 compliant   |
| Pulse inputs 1 and 2   | Dry form A and solid-state form A compatible<br>Maximum frequency 10 Hz<br>Minimum pulse width 20 ms  | Dry form A and solid-state form A compatible<br>Maximum frequency 10 Hz<br>Minimum pulse width 20 ms  |
| Non-volatile memory storage  | 120 days in 15-minute intervals   | 120 days in 15-minute intervals   |
| Onboard modem  | V.90  | V.90  |
| Onboard Ethernet port  | 10/100 Mb/s   | 10/100 Mb/s   |
| Serial port  | 115 kb/s  | 115 kb/s  |
| Fuse rating (F1)   | North America: 120V: T125 mA, 250V<br>International 230V: T63 mA, 250V                                | North America: 120V: T125 mA, 250V<br>International 230V: T63 mA, 250V  |
| <b>Environmental</b>   |   |   |
| Operating temperature  | -40 to 70°C   | -40 to 70°C   |
| Operating humidity   | 5% to 90% non-condensing  | 5% to 90% non-condensing  |
| Usage environment  | Indoor or enclosed outdoor environment  | Indoor or enclosed outdoor environment  |
| Maximum altitude   | 9843 ft (3000 m)  | 9843 ft (3000 m)  |
| Pollution degree   | 2   | 2   |

### Front Panel Display

The PowerHawk 6203 and 6303 meters have the following front panel features (Figure 1 shows the PowerHawk 6303 front panel):

- **LCD** — displays 2 rows of 16 characters for each of the meter points (2, 3, or 6)
- **Display button** — cycles through the available information for each of the meter points
- **Left and right arrow buttons** — selects which of the meter points is on the display

Figure 1: PowerHawk 6303 front panel

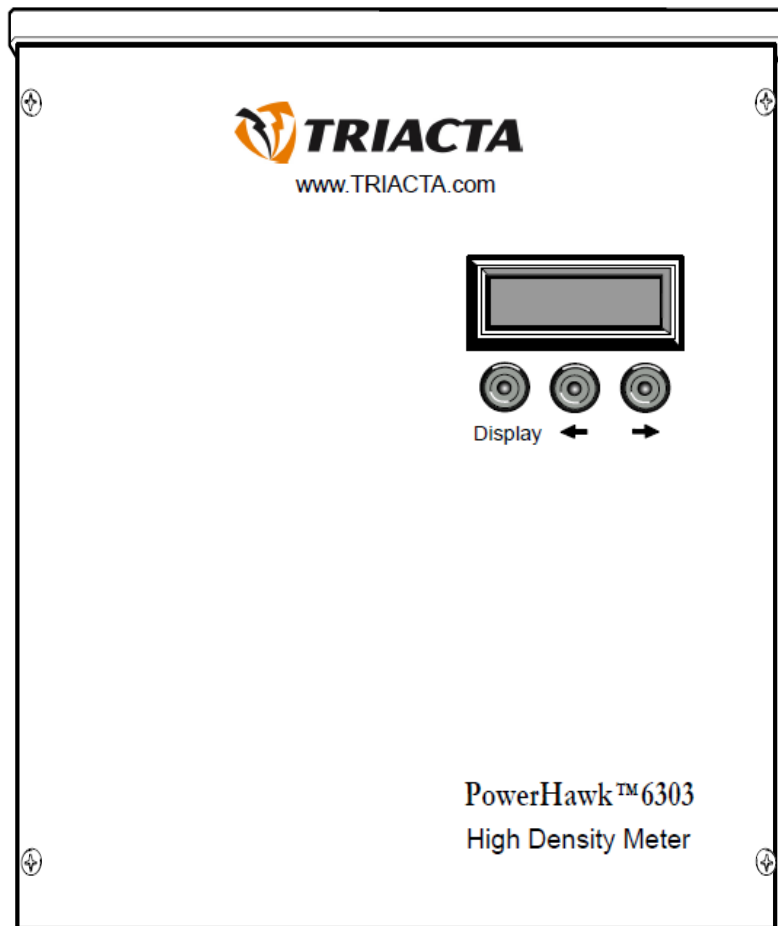
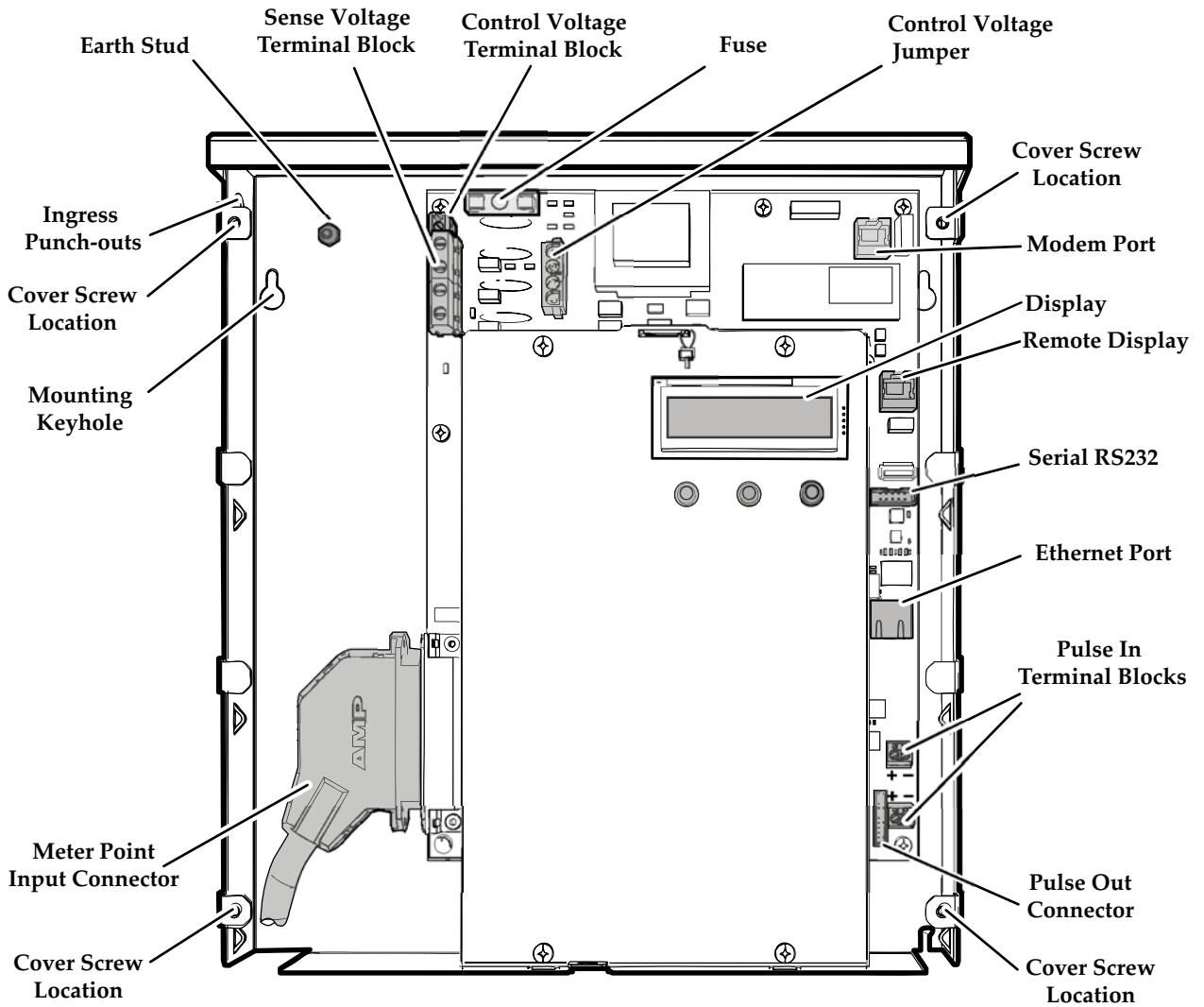

Figure 2 shows the internal view of the PowerHawk 6203 and PowerHawk 6303.

Figure 2: PowerHawk 6203 and PowerHawk 6303 internal view



## SAFETY PRECAUTIONS

Carefully observe these safety instructions.

### **⚠ DANGER**

#### **HAZARD OF ELECTRIC SHOCK, EXPLOSION, OR ARC FLASH**

- Apply appropriate personal protective equipment (PPE) and follow safe electrical work practices. See NFPA 70E.
- Only qualified electrical workers should install this equipment. Such work should be performed only after reading this entire set of instructions.
- The equipment must be accessible to authorized personnel only. Equipment must be installed in areas where access can be restricted.
- NEVER work alone.
- Before performing visual inspections, tests, or maintenance of this equipment, disconnect all sources of electric power. Assume that all circuits are live until they have been completely de-energized, tested, and tagged. Pay particular attention to the design of the power system. Consider all sources of power, including the possibility of backfeeding.
- Turn off all power supplying the meter and the equipment in which it is installed before working on it.
- Always use a properly rated voltage sensing device to confirm that all power is off.
- Before closing all covers and doors, carefully inspect the work area for tools and objects that may have been left inside the equipment.
- Successful equipment operation requires proper handling, installation, and operation. Neglecting fundamental installation requirements can lead to personal injury as well as damage to electrical equipment or other property.
- NEVER bypass external fusing.
- NEVER short the secondary of a Potential Transformer (PT).
- Always short the secondary of a current transformer prior to disconnecting current input loads.

**Failure to follow these instructions will result in death or serious injury.**

#### **Electrical Safety Compliance**

- Use the unit only in accordance with the electrical power rating
- The unit is only to be installed by a qualified electrician
- Initial installation of the unit must be inspected by the local electrical Inspection Authority
- Install the unit in compliance with the following local and national electrical codes:
  - Canada: Canadian Electrical Code, Part I, CSA C22.1
  - United States: National Fire Protection Association (NFPA) 70; US National Electrical Code
  - Elsewhere: International Electrotechnical Commission (IEC) 364, Part 1-7
- Ensure that the unit is properly earthed
- If the equipment is installed or used in a manner other than that specified in this document, it may void your warranty or impair the protection of the equipment.

## INSTALLATION

This section contains the following installation topics:

- “Pre-Installation” on page 6
- “Installation Procedures” on page 7
- “Start-Up Sequence” on page 25

### Pre-Installation

The pre-installation checklist and site planning must be performed before installing the equipment at the site.

### Receiving

The equipment required for each PowerHawk meter installation includes:

- high-density meter (PowerHawk 6203 or PowerHawk 6303)
- one 12-ft (4-m) AMP cable with one 50-pin connector supplied with each unit
- CD and meter configuration software, this installation manual and an installation record form

When you receive your order, verify that the items listed above are included with the shipment, and visually inspect them for damage. If any parts are missing or damaged, contact your Triacta representative.

### Pre-Installation Checklist

The installer must provide the following information, tools, and equipment before proceeding with the installation:

- certified current transformers for metering (not supplied)
- an appropriate 15-Amp maximum circuit breaker or a fused disconnect switch for the type of panel
- current/voltage meter to test the phasing of panels
- RJ45 Ethernet patch cable
- 4-wire 14 AWG (1.63 mm<sup>2</sup>) cable for three-phase wye connected circuits, or 3-wire 14 AWG (1.63 mm<sup>2</sup>) cable for a single-phase wye connected circuits
- small flat-head screwdriver
- #2 Phillips screwdriver
- crimping tool
- 18 AWG butt splice connector
- wire strippers
- four 1-inch (25 mm) #8 mounting screws suitable for selected mounting surface

If using a modem, these items are also required:

- phone or butt set to test the phone line
- RJ11 junction box
- RJ11 splitter to tap into the existing junction box
- RJ11 patch cable
- xDSL filter if required (many businesses have their internet access on the same line as the fax)

### Site Planning

1. Determine the number of PowerHawk 6203 and 6303 meters to be installed and ensure adequate space. For clearances, see Figure 3 on page 9.

2. Determine the number of analog phone lines or Ethernet drops required, and ensure they are installed before installing the PowerHawk 6203 and 6303 meters. The recommended maximum number of PowerHawk meters per phone line is 50.
3. Determine the number and types of meters or monitors required (single-phase, network, or three-phase).
4. Determine the model number and correct sense voltage based on the voltage label on the top right side of the unit.

#### **Access to Power and Lighting**

The installation site must be supplied with access to the main electrical panel and any sub-panels. Portable or permanent lighting must be available to provide the installers with a clear view of the equipment and of the installation environment. Each installation may vary depending on physical site restrictions.

## **Installation Procedures**

This section provides information about activities that must be performed to install the PowerHawk 6203 and 6303 meters in a single-phase 2-wire, single-phase 3-wire (network), or three-phase 4-wire application. The installation procedures must be performed in the following order:

1. "Mounting the PowerHawk Meters" on page 8
2. "Installing Potential Transformers for Three-Phase Service Greater Than 277V" on page 10
3. "Installing the Sense Voltage and Control Voltage Cables in Wye and Delta Services" on page 12
4. "Installing the Current Transformers" on page 20
5. "Connecting the Communications" on page 25
  - a. "Connecting the Phone Line" on page 25
  - b. "Connecting the Ethernet Cable" on page 25
  - c. "Manually Testing Communications" on page 25
6. "Start-Up Sequence" on page 25
7. "Completing the Installation Record" on page 27

### Mounting the PowerHawk Meters

Figure 3 shows the general mounting layout for metering 120V/208V wye services, and Figure 5 shows the general mounting layout for metering 347V/600V wye services.

1. Mount the PowerHawk meter and the shorting block enclosure adjacent to the main circuit breaker box using the 1-inch (25-mm) #8 screws. If mounting the unit on a plasterboard surface, use cylinder plugs.
2. Remove the front cover from the meter by removing the four screws with a #2 Phillips screwdriver. Retain the cover and screws for later re-installation.
3. Mount the PowerHawk meter on the wall and secure it by inserting a screw in each mounting keyhole and tightening the screws.
4. Mount the shorting block enclosure on the wall as shown in Figures 3 and 5. Secure it by inserting a screw in each mounting keyhole and tightening the screws.

In Figure 3, the meter is powered and takes its sense voltage directly from a breaker within the panel.

Figure 3: 120V Mounting Layout, Dimensions and Clearances

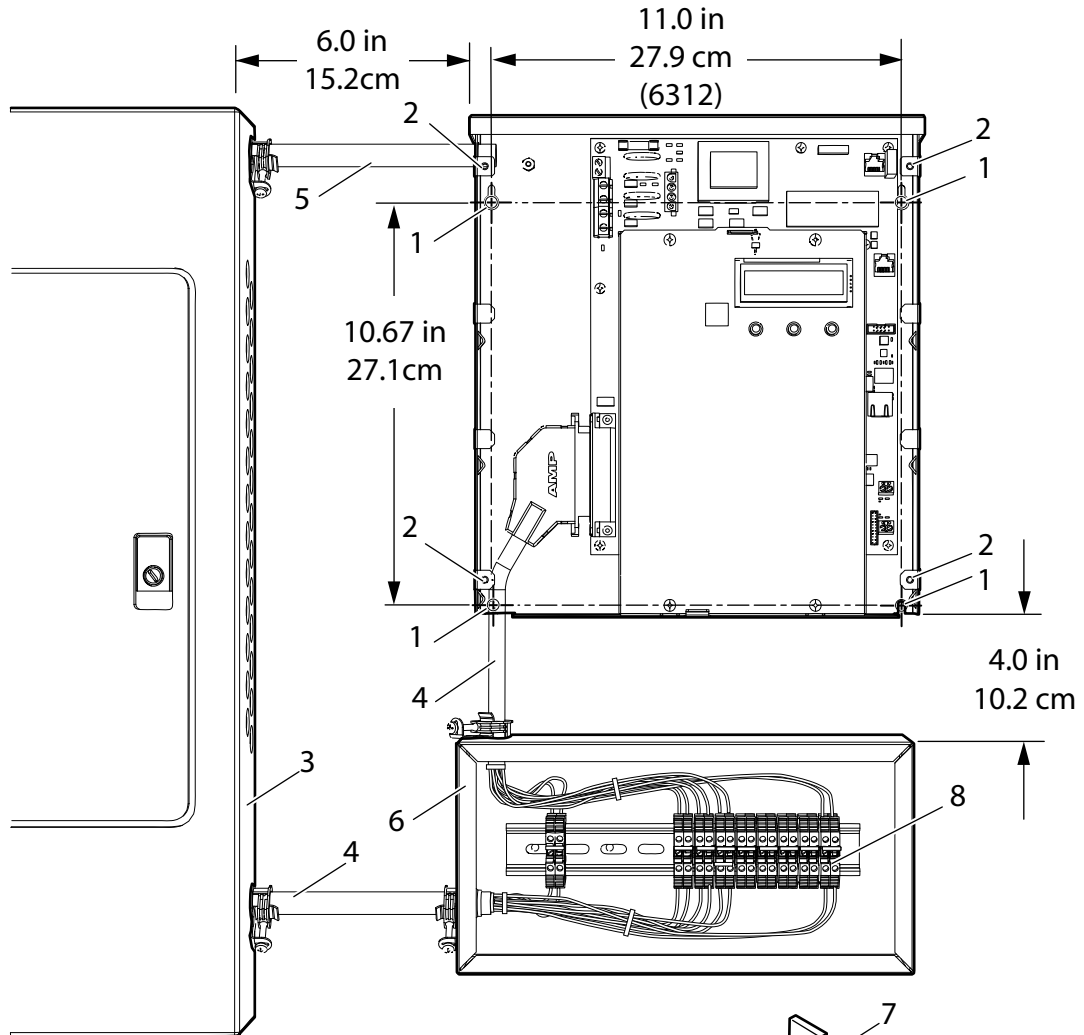

Legend:

- 1. Mounting keyhole
- 2. Cover screw location
- 3. Electrical distribution panel
- 4. CT conduit
- 5. Power conduit
- 6. Shorting block enclosure
- 7. Shorting jumper
- 8. Shorting block
- 9. DIN rail

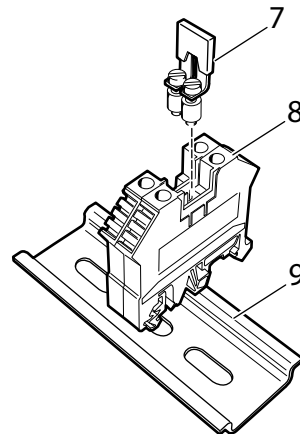

**Installing Potential Transformers for  
Three-Phase Service Greater Than 277V**

Potential transformers are required when metering services greater than the rated input of the meter. Potential transformers are used to reduce the line-to-neutral voltage of the service to 120V. The accuracy class should be 0.3% or better, with a burden rating of 30VA.

For applications in Canada, Measurement Canada approved potential transformers are required. Measurement Canada requires an accuracy class of 0.3% or better, with a 150VA rating.

*NOTE: Potential transformer burden depends on the control voltage source. If control voltage is provided separately (not derived from the metered voltage), then lower transformer burden may be acceptable. Contact your local Triacta representative for details.*

Potential transformers must be mounted in a listed electrical enclosure as shown in Figure 4.

**Figure 4: Potential transformer chassis**

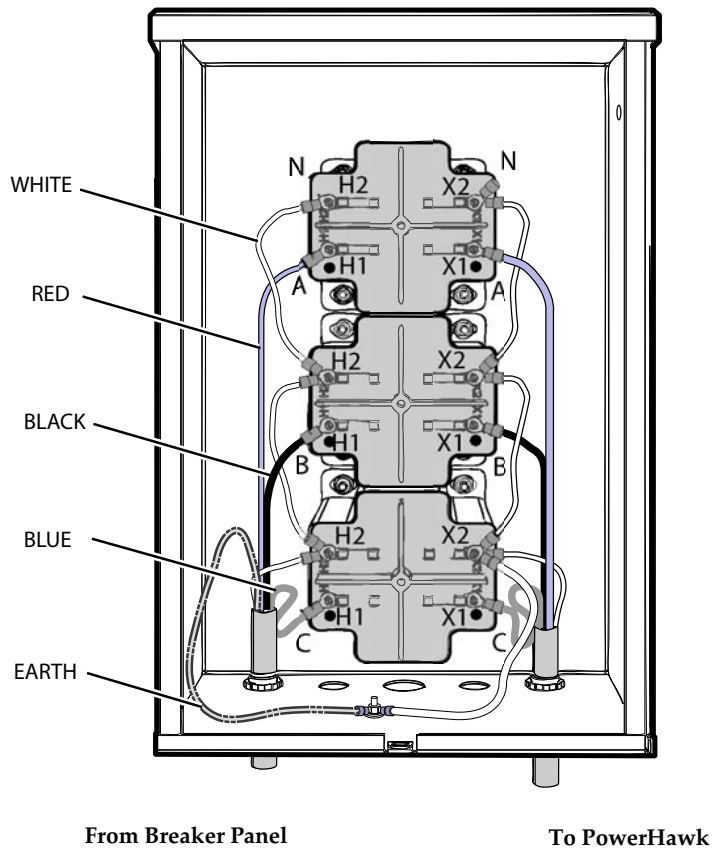

Mount the potential transformer enclosure between the supply voltage and the PowerHawk meters as shown in Figure 5. Transformer configuration must be Y||Y (wye-wye).

In Figure 5, the meter is powered from the potential transformers that are fed from a breaker within the 347V/600V panel. The CT cable is connected to the shorting enclosure before connecting to the CTs in the panel.

Figure 5: Typical three-phase 347V installation

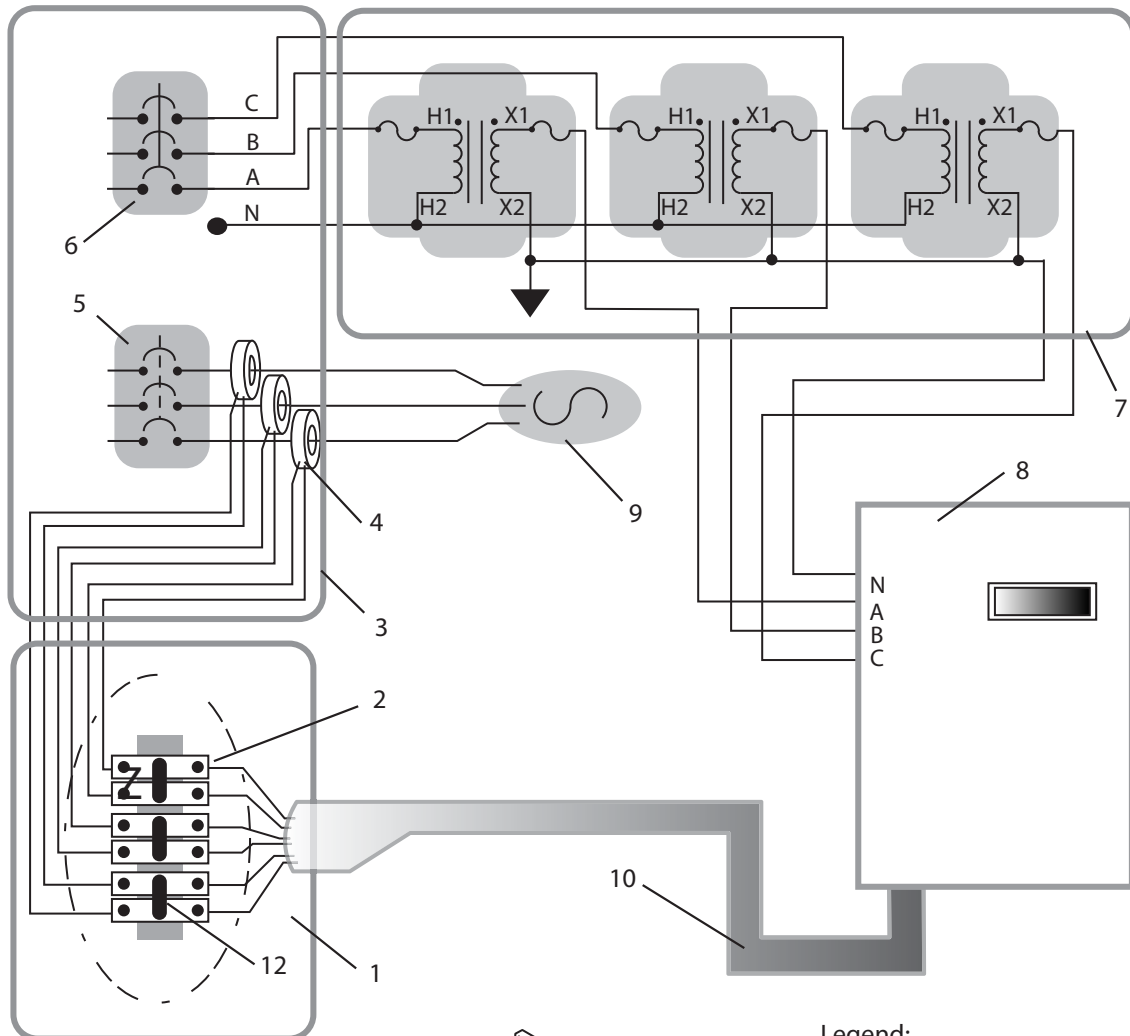

Shunting block detail

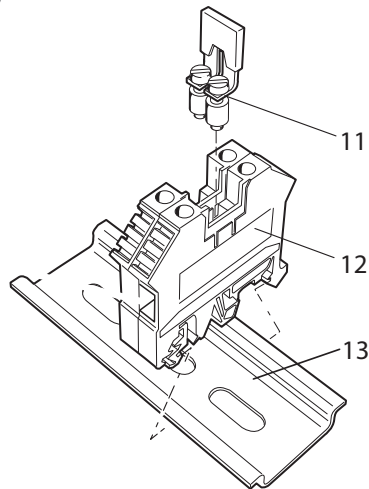

Legend:

- 1 Shunting block enclosure
- 2 Shunting block
- 3 Breaker panel
- 4 Current transformer
- 5 Load breaker
- 6 Meter breaker
- 7 Transformer enclosure
- 8 PowerHawk meter
- 9 Load
- 10 Cable
- 11 Shunting jumper
- 12 Shunting block
- 13 DIN rail

### Installing the Sense Voltage and Control Voltage Cables in Wye and Delta Services

The sense voltage (A, B, C, N) provides phase voltages for metering. The configuration depends on the type of service being metered:

- see “For a single-phase panel with the 120V variant of the meter:” on page 14
- see “For a 120/208V three-phase wye panel with the 120V variant of the meter:” on page 15
- see “For a 240/416V three-phase wye panel with the 230/240V variant of the meter:” on page 16
- see “For a 277/480V three-phase wye panel with the 120V variant of the meter:” on page 17
- see “For a 347/600V or higher three-phase wye panel with potential transformers with the 120V variant of the meter:” on page 18
- see “For a three-phase Delta panel with the 120V variant of the meter:” on page 19

The PowerHawk 6203 and 6303 meters are shipped from the factory with a control voltage jumper that can be used to connect the control voltage input and the sense voltage inputs to provide control voltage to the unit. The following procedures explain how to connect the sense voltage inputs for each of the service types.

For a single-phase panel, use a 3-wire (red, black, white), 14 AWG (1.63 mm<sup>2</sup>), 90°C (194°F) cable. For a three-phase panel, use a 4-wire (red, black, blue, white), 14 AWG (1.63 mm<sup>2</sup>), 90°C (194°F) cable. For a Delta service, use a 3-wire (red, black, blue), 14 AWG (1.63 mm<sup>2</sup>), 90°C (194°F) cable. Metallic, flexible armored cable (BX cable) is recommended for commercial installations as shown in Figure 6 on page 14.

The PowerHawk meters must be connected to the sense voltage and control voltage through a properly rated disconnect that disconnects all line and neutral wires, so it can be powered down. The disconnect must be located within easy reach of the meter operator, and must be labeled as such. Opening the disconnect or breaker is the disconnect device. For multiple PowerHawk meter installations, the same disconnect can be used to power all meters, and must be labeled for all meters it supplies power to. The disconnect device must meet IEC 60947-1, IEC 60947-3 and/or comply with the local electrical code.

To install the control voltage cable in a 120/208V or 120/240V application:

| <b>⚠ DANGER</b>  |
|--|
| <b>HAZARD OF ELECTRIC SHOCK, EXPLOSION, OR ARC FLASH</b>   |
| <ul style="list-style-type: none"><li>• Apply appropriate personal protective equipment (PPE) and follow safe electrical work practices. See NFPA 70E.</li><li>• This equipment must only be installed and serviced by qualified electrical personnel.</li><li>• Turn off all power supplying this equipment before working on or inside equipment.</li><li>• Always use a properly rated voltage sensing device to confirm power is off.</li><li>• Replace all devices, doors and covers before turning on power to this equipment.</li><li>• The meters must be connected to the sense voltage and control voltage through a properly rated voltage disconnect (not shown in the wiring diagrams).</li></ul> |
| <b>Failure to follow these instructions will result in death or serious injury.</b>  |

*NOTE: If the circuit breaker panel does not designate phase A, phase B and phase C feeds, make your own designation and use it for the rest of the installation.*

1. Before connecting the sense voltages, turn off the power to the circuit being connected.
2. Always use a properly rated voltage sensing device to confirm power is off.
3. Connect the sense voltages phase A, B, C, and N leads from the voltage disconnect to the meter as described in Figure 6 on page 14 and Figure 7 on page 15.

*NOTE: The phase wiring sequence A, B, C between the PowerHawk meter and the panel must match or the measurement readings will be wrong.*

4. If more than one meter is being installed, repeat this procedure for each additional meter.

**For a single-phase panel with the 120V variant of the meter:**

- Connect meter terminal A to the voltage disconnect phase A (red wire)
- Connect meter terminal B to the voltage disconnect phase B (black wire)
- Connect meter neutral terminal to neutral bar in the voltage disconnect panel (white wire)
- Connect earth wire to earth post using lug provided
- Meter terminal C is not connected
- Install power supply shorting jumpers (see Figure 6)

The PowerHawk 6203 and 6303 meters are rated for direct input of 120V to 277V 60Hz phase potential. When metering services greater than 120V, the meter is powered from a separate 120V instrument transformer. Figure 9 shows the wiring of the control voltage transformer for a service between 240V and 277V.

**Figure 6: PowerHawk meter in a 120/240V single-phase connection**

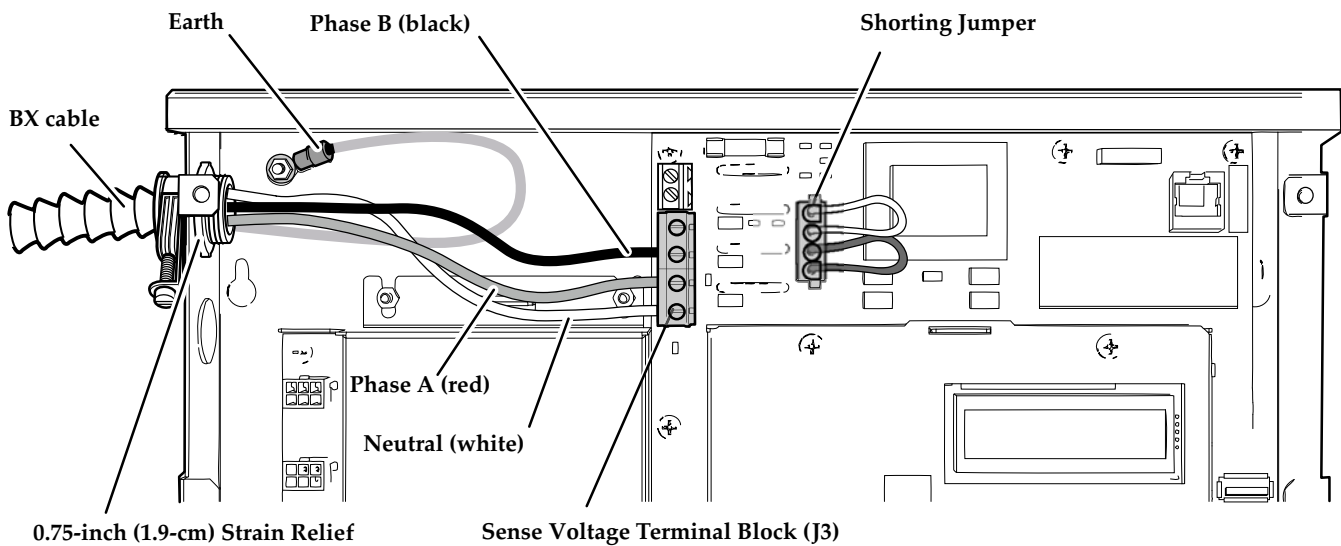

**For a 120/208V three-phase wye panel with the 120V variant of the meter:**

- Connect meter terminal A to the voltage disconnect phase A (red wire)
- Connect meter terminal B to the voltage disconnect phase B (black wire)
- Connect meter terminal C to the voltage disconnect phase C (blue wire)
- Connect meter neutral terminal to neutral bar in the voltage disconnect panel (white wire)
- Connect earth wire to earth post using lug provided
- Install power supply shorting jumpers (see Figure 7)

**Figure 7: PowerHawk meter 120/208V three-phase wye service connection**

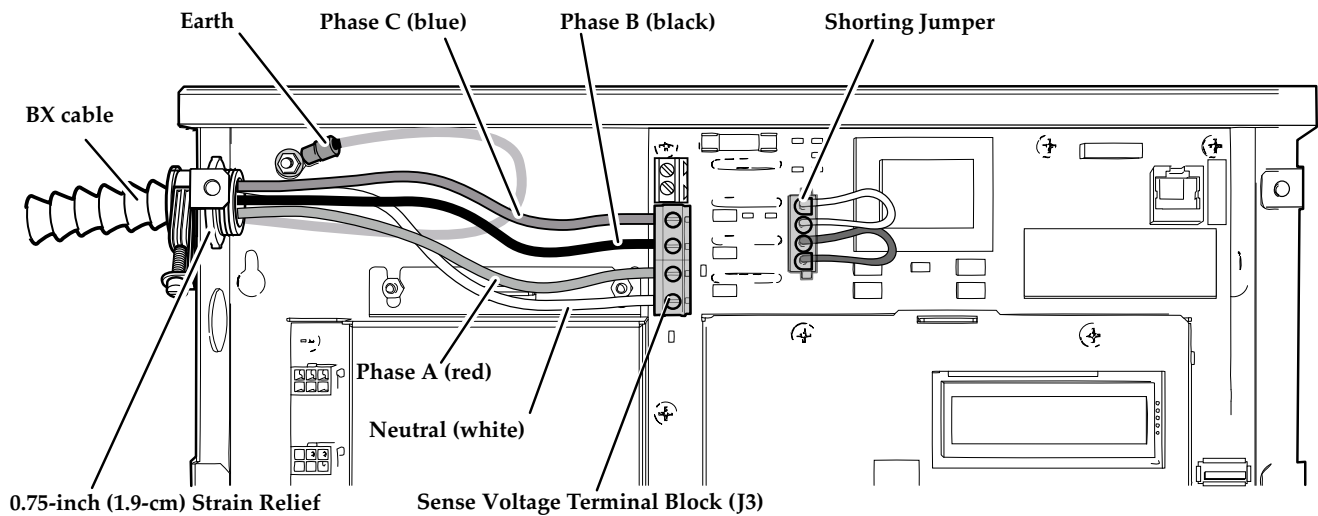

**For a 240/416V three-phase wye panel with the 230/240V variant of the meter:**

- Connect meter terminal A to the voltage disconnect phase A (red wire)
- Connect meter terminal B to the voltage disconnect phase B (black wire)
- Connect meter terminal C to the voltage disconnect phase C (blue wire)
- Connect meter neutral terminal to neutral bar in the voltage disconnect panel (white wire)
- Connect earth wire to earth post using lug provided
- Install power supply shorting jumpers (see Figure 8)

**Figure 8: PowerHawk meter 240/416V three-phase wye service connection**

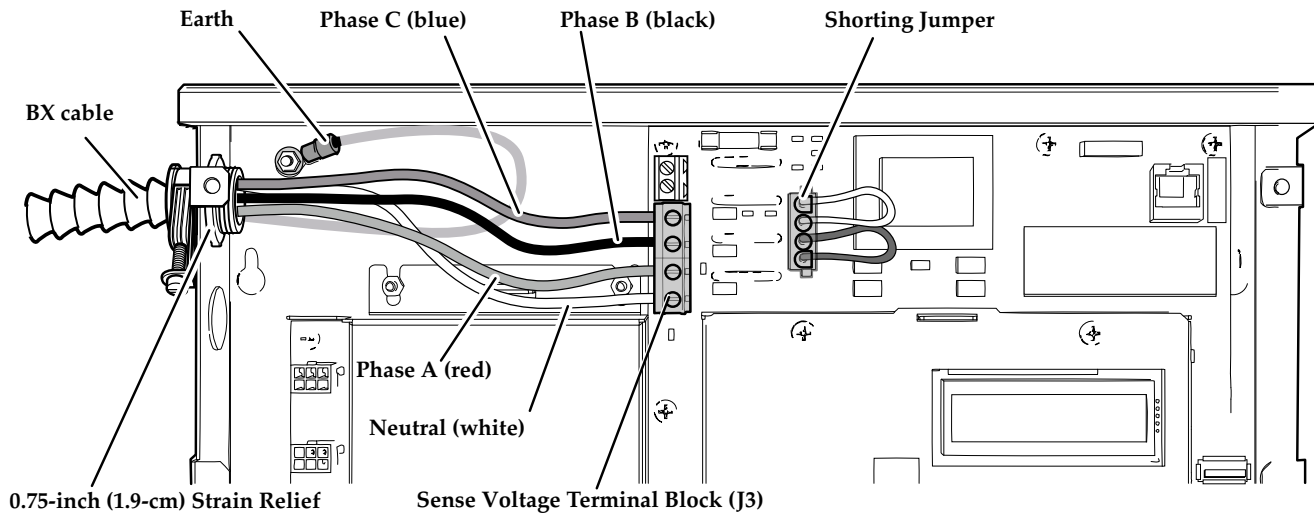

**For a 277/480V three-phase wye panel with the 120V variant of the meter:**

- Connect meter terminal A to the voltage disconnect phase A (red wire)
- Connect meter terminal B to the voltage disconnect phase B (black wire)
- Connect meter terminal C to the voltage disconnect phase C (blue wire)
- Connect meter neutral terminal to neutral bar in the voltage disconnect panel (white wire)
- Connect earth wire to earth post using lug provided
- From the auxiliary power transformer, connect 120V auxiliary power to AUXA and AUXN on the meter (see Figure 9)

**Figure 9: PowerHawk meter 277/480V three-phase wye service connection**

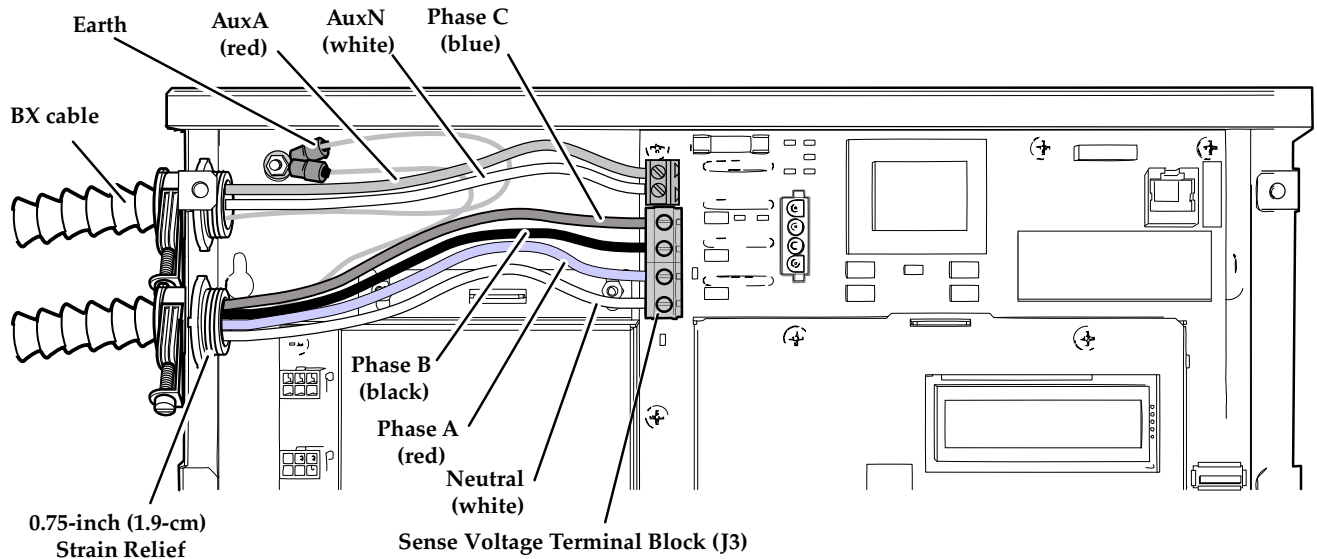

**For a 347/600V or higher three-phase wye panel with potential transformers with the 120V variant of the meter:**

- Connect meter terminal A to the voltage disconnect phase A (red wire)
- Connect meter terminal B to the voltage disconnect phase B (black wire)
- Connect meter terminal C to the voltage disconnect phase C (blue wire)
- Connect meter neutral terminal to neutral bar in the voltage disconnect panel (white wire)
- Connect earth wire to earth post using lug provided
- Install power supply shorting jumpers (see Figure 10)

*NOTE: For the wiring of the potential transformers, see Figure 5.*

**Figure 10: PowerHawk meter 347/600V or higher three-phase wye service with potential transformers connection**

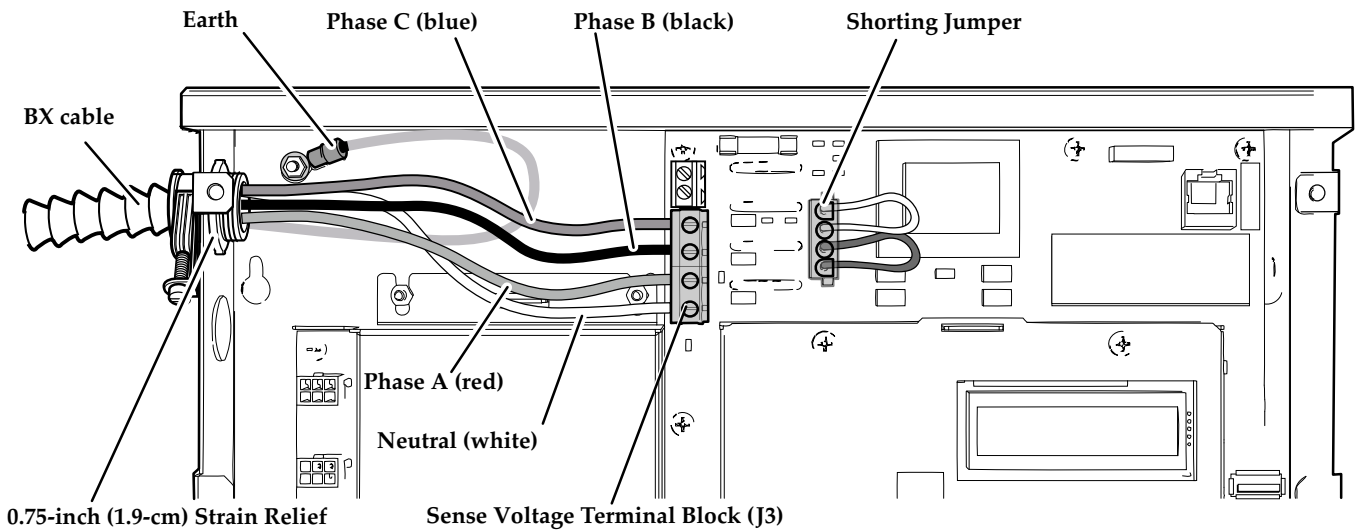

### Delta service metering

To use the PowerHawk meter in a Delta service, the line-to-line voltage from the Delta service must be reduced to 120V line-to-line using appropriate potential transformers. Metering a Delta service requires only two potential transformers, and only two CTs for phase A and C. Using the phase B CT is optional.

#### For a three-phase Delta panel with the 120V variant of the meter:

- Connect meter terminal A to the voltage disconnect phase A (red wire)
- Connect meter terminal C to the voltage disconnect phase C (blue wire)
- Connect meter neutral terminal to meter terminal B (black wire)
- Connect earth wire to earth post using lug provided
- Install power supply shorting jumpers (see Figure 11)

Figure 11: PowerHawk meter three-phase Delta service connection

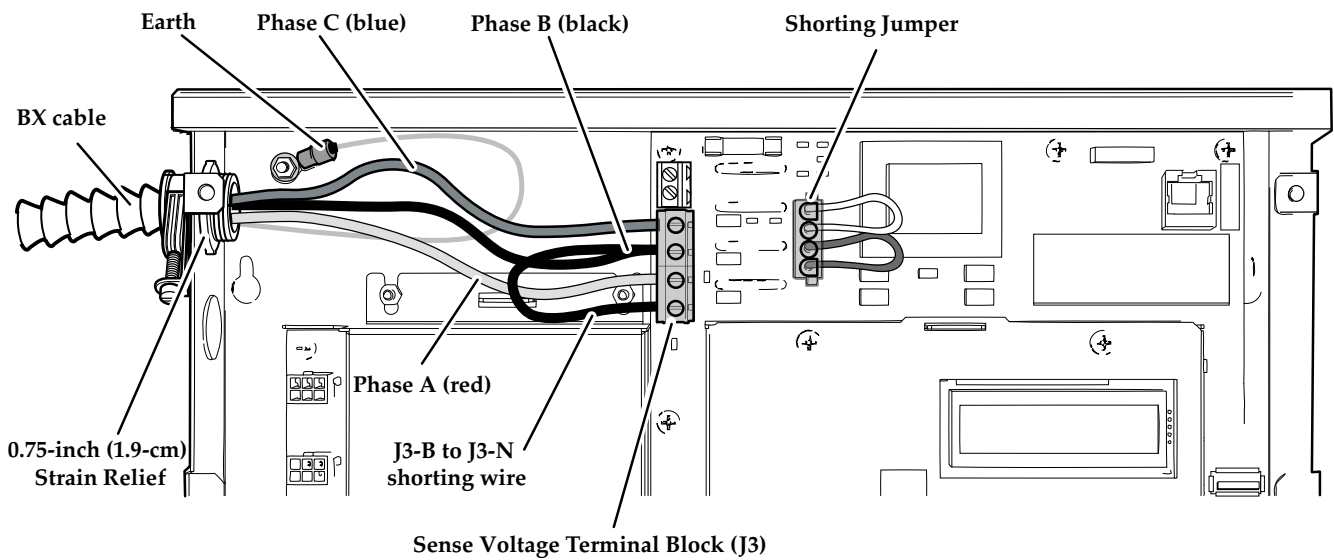

## Installing the Current Transformers

The three models of PowerHawk meter use current transformers (CTs) with different secondary outputs. The PowerHawk 6203 meter uses split-core 0.333V CTs (see Figure 12), and the PowerHawk 6303 meter uses 80mA CTs only (see Figure 13) and is typically used where accuracy is important and long secondary CT wiring is required (up to 300 feet [91.44 meters]). The PowerHawk 6303 meter can also use a 5A CT if a 5A converter has first been installed.

For instructions, see “Installing the CTs on the PowerHawk 6203 and PowerHawk 6303” on page 21, and “Installing 5A Converters and CTs on the PowerHawk 6303” on page 22.

Current transformers connect to the PowerHawk 6203 and PowerHawk 6303 meters through the 50-conductor CT cable provided with the meter. Table 2 describes the CT wire pairs and the cable color scheme for each meter point. You can also find this information on the inside of the meter’s outer cover.

Each CT has an X1 (positive) and X2 (neutral) wire pair and uses butt-splice connectors to attach the CT to a specific meter wire pair. The direction of the energy flow is indicated on the CT.

**Figure 12: PowerHawk 6203 split-core 0.333V current transformer**

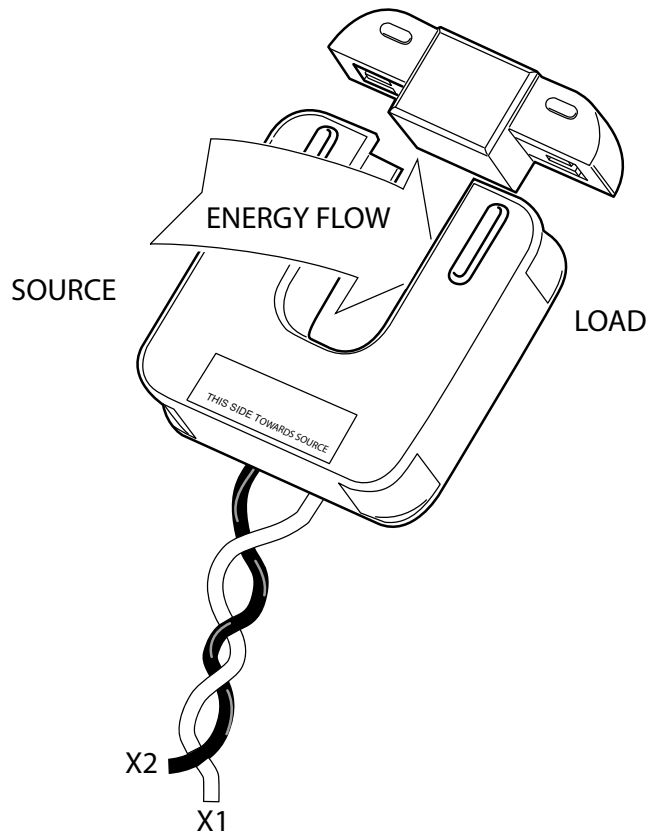
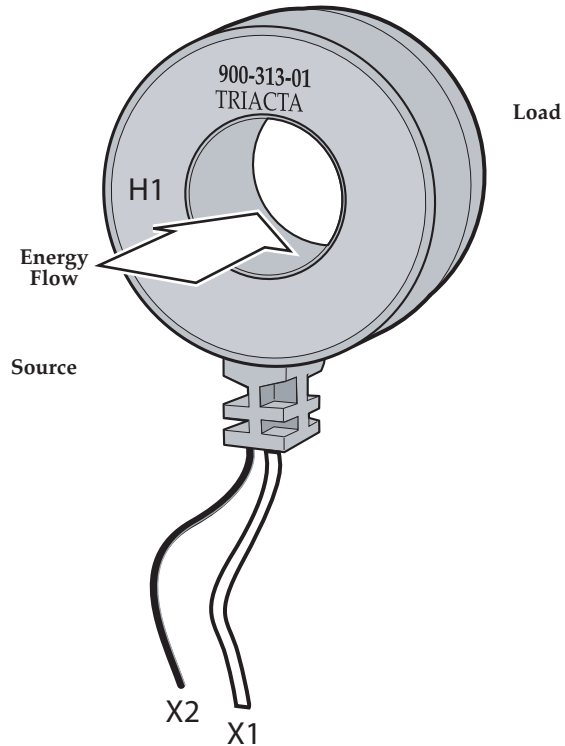

Figure 13: PowerHawk 6303 mA current transformer



**Installing the CTs on the PowerHawk 6203 and PowerHawk 6303**

Do not apply power until you have made these connections and followed all of the instructions below:

- Connect all CTs to the appropriate circuits
- Connect the CTs to the cables
- Connect the cables to the PowerHawk meter

To install the mA current transformers on the PowerHawk 6303 or the 0.333V current transformers on the PowerHawk 6203, follow these steps:

|  |
|--|
| <b>⚠ DANGER</b>  |
| <b>HAZARD OF ELECTRIC SHOCK, EXPLOSION, OR ARC FLASH</b>   |
| <ul style="list-style-type: none"><li>• Turn off all power supplying this equipment before working on or inside the equipment.</li><li>• Always use a properly rated voltage sensing device to confirm the power is off.</li><li>• NEVER open circuit a CT; use the shorting block to short circuit the leads of the CT before removing the connection from the meter.</li><li>• Do not crimp the insulation when making the wire connections.</li></ul> |
| <b>Failure to follow these instructions will result in death or serious injury.</b>  |

1. Connect the 50-pin connector to the PowerHawk connector located at the bottom side of the unit, and secure it in place with the retaining clips.
2. Feed the free end of the cable through the bottom left of the meter enclosure.  

This cable is made up of twisted-pair wires for connecting the individual CTs to the metered points. The color codes for the X1 (positive) and X2 (neutral) connections for each CT are listed in Table 2 on page 23.

*NOTE: The direction of the energy flow is indicated on the CT.*
3. Turn off the power feed to the panel where the CTs are being installed. Always use a properly rated voltage sensing device to confirm power is off.
4. Feed the CT cable into the panel through an appropriate punch-out with an approved strain relief.
5. Strip the plastic sheaths on the cable to an appropriate length to expose the wire pairs. Cut and strip the CT leads and wire pair leads to an appropriate length. Crimp the CT leads to the wire pairs for each meter point.
6. Connect the X1 lead of the CT to the X1 lead of the cable, then connect the X2 lead of the CT to the X2 lead of the cable (see Table 2).
7. When using solid-core CTs, remove the feed wire from the circuit breaker, place the CT over the wire, and reconnect to the circuit breaker. Ensure that the arrow on the CT label is pointing in the direction of the energy flow (toward the load).
8. When using split-core CTs, separate the halves of the CT and place the CT over the wire to the circuit breaker. Ensure that the CT is facing the source as shown on the label. Install cable ties to ensure that the CT halves are held together securely.
9. Repeat steps 5 to 8 for the remaining CTs.

#### **Installing 5A Converters and CTs on the PowerHawk 6303**

When both low-current (200A and 400A) and high-current (600A or higher) circuits need to be measured with the same PowerHawk meter, converters are available to allow the use of Measurement Canada approved 5A CTs with the appropriate current rating. 5A CT converters transform the 5A maximum output from a standard CT to the 80mA maximum of the PowerHawk meter.

The 5A side of the converter is the black and red wire pair, and the 80mA side of the converter is the black and white wire pair.

*NOTE:* It is recommended that 5A converters and shorting devices be installed in a sealable metal enclosure.

To connect the 5A CT to the converter on the PowerHawk 6303, follow these steps:

**⚠ DANGER**

**HAZARD OF ELECTRIC SHOCK, EXPLOSION, OR ARC FLASH**

- Turn off all power supplying this equipment before working on or inside the equipment.
- Always use a properly rated voltage sensing device to confirm the power is off.
- NEVER open circuit a CT; use the shorting block to short circuit the leads of the CT before removing the connection from the meter.
- Do not crimp the insulation when making the wire connections.

**Failure to follow these instructions will result in death or serious injury.**

1. Connect the X1 lead of the 5A CT to the shorting device.
2. Connect the X2 lead of the 5A CT to the shorting device.
3. Connect the X1 lead (red) from the 5A side of the converter to the CT X1 lead on the shorting device.
4. Connect the X2 lead (black) from the 5A side of the converter to the CT X2 lead on the shorting device.
5. Connect the X1 lead (white) from the 80mA side of the converter to the X1 lead within the 25 pair cable for the selected meter point ID listed in Table 2.
6. Connect the X2 lead (black) from the 80mA side of the converter to the X2 lead within the 25 pair cable for the selected meter point ID listed in Table 2

Figure 14 shows a 5A CT connected to the converter.

**Table 2: PowerHawk 6203 and PowerHawk 6303 CT color pair identification**

| 1-phase, 6 meter points                |                        |                        | Network- or 1-phase, 3 meter points    |                        |                        | 3-phase, 2 meter points                |                        |                        |
|--|------------------------|------------------------|--|------------------------|------------------------|--|------------------------|------------------------|
| Meter point ID (meter point #-probe #) | Connect X1 CT lead to: | Connect X2 CT lead to: | Meter point ID (meter point #-probe #) | Connect X1 CT lead to: | Connect X2 CT lead to: | Meter point ID (meter point #-probe #) | Connect X1 CT lead to: | Connect X2 CT lead to: |
| 1-1                                    | Black                  | Green                  | 1-1                                    | Black                  | Green                  | 1-1                                    | Black                  | Green                  |
| 2-1                                    | Black                  | White                  | 1-2                                    | Black                  | White                  | 1-2                                    | Black                  | White                  |
| 3-1                                    | Black                  | Red                    | 2-1                                    | Black                  | Red                    | 1-3                                    | Black                  | Red                    |
| 4-1                                    | Red                    | Green                  | 2-2                                    | Red                    | Green                  | 2-1                                    | Red                    | Green                  |
| 5-1                                    | Red                    | White                  | 3-1                                    | Red                    | White                  | 2-2                                    | Red                    | White                  |
| 6-1                                    | Black                  | Orange                 | 3-2                                    | Black                  | Orange                 | 2-3                                    | Black                  | Orange                 |

Figure 14: PowerHawk 6303 5A CT connection to converter

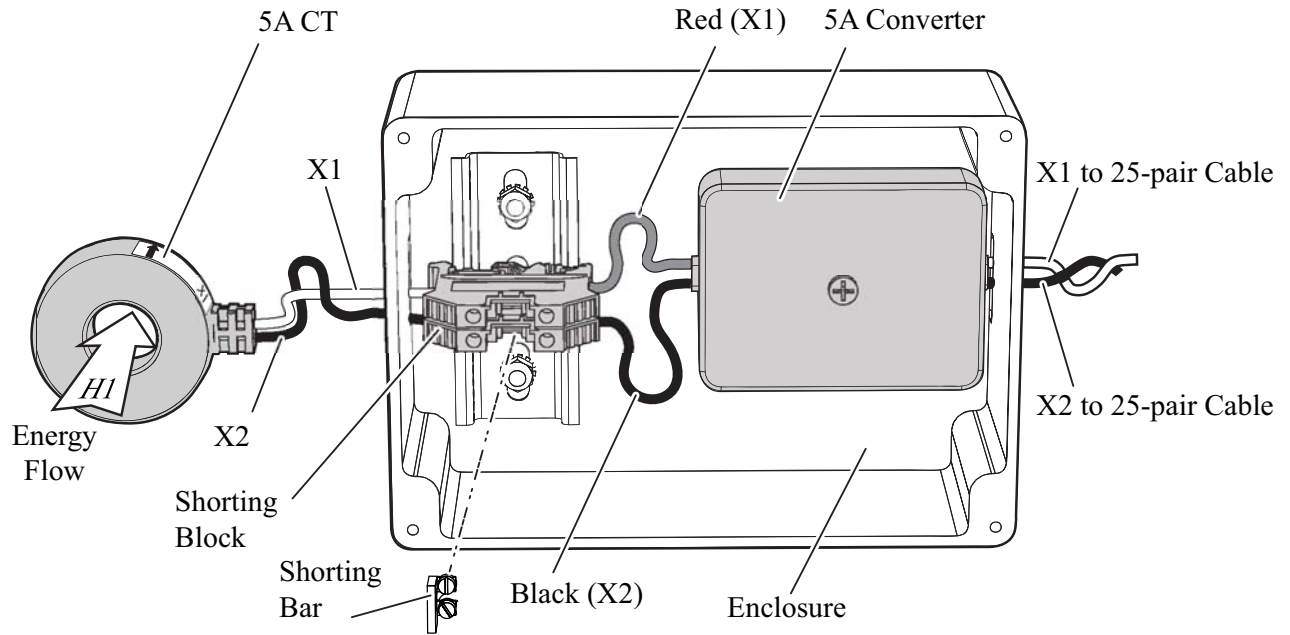

## Connecting the Communications

Connections for communications using the modem or Ethernet are described in this section.

### Connecting the Phone Line

If the modem reporting option is being used, an analog telephone patch cable and a splitter may be required to connect the customer phone line to the PowerHawk meter.

1. Connect the patch cable between the termination block of the phone line and the PowerHawk meter.
2. Route the cable through the slot in the PowerHawk meter enclosure.
3. See the PowerHawk meter Configuration Guide for instructions on how to program the meter for dial-out operation before performing a manual configuration test.

### Connecting the Ethernet Cable

If the Ethernet port is used to report data, an RJ45 patch cable is required to connect the Ethernet port to the local Ethernet network.

1. Route the cable through the slot in the PowerHawk meter enclosure.
2. If the local network automatically assigns IP addresses through a DHCP server, the PowerHawk meter will be able to report using its factory default IP settings. If the local network is configured for static IP addresses, refer to the PowerHawk meter Configuration Guide for instructions on how to configure default static IP addresses.

## Start-Up Sequence

Use the following procedure to start up the PowerHawk meter.

1. Ensure that all CT and sense voltage wiring is securely installed.
2. Remove all tools from the work area.
3. Re-install all cover plates and equipment covers.
4. Power up the meter. The LCD on the front panel of the meter indicates the operating status of the unit as follows:
  - a. Initial power up message "PowerHawk 6X03"
  - b. After the internal configuration is complete, the display shows default information for the first meter.

### Manually Testing Communications

This procedure clears the meter memory, manually tests the communications from the PowerHawk meter, and updates the meter clock. To force the meter to send data, follow these steps:

1. Press and hold the Display button for 5 to 7 seconds until the diagnostics mode is displayed, then release.
2. If communicating via Ethernet, press the Display button until "Local IP Address" appears on the display.
  - a. If the IP address is 192.168.0.9, the meter has not found a DHCP server. As a result, the meter will use its default IP configuration and may not be able to report. See the PowerHawk meter Configuration Guide for instructions on how to program default IP addresses.
  - b. If the IP address is not 192.168.0.9, the meter has acquired an IP address from the local network, and will be able to report data and synchronize time.

3. Press the Display button until the "Send" command appears on the display.
4. Press the center or the right arrow button to manually force the PowerHawk meter to report metering data using the Ethernet or modem connection. This clears data from the PowerHawk meter memory, and ensures the time is set correctly.

## Pulse Inputs

There are two pulse in terminal blocks in the PowerHawk meter, as shown in Figure 2. Each terminal block has a negative terminal pin on the right and a positive terminal pin on the left. The pulse inputs are compatible with both dry and solid-state form A contacts, 10 Hz (maximum), 20 ms pulse width (minimum). The inputs are not polarity-sensitive to dry relay contacts. When the pulsing device provides solid-state form A outputs, the negative terminal from the source device must be connected to the negative terminal of the PowerHawk meter pulse in terminal block.

## Display Navigation

The PowerHawk meter has three buttons to control the information presented on the LCD. The display has a normal and a diagnostics mode. The PowerHawk meter starts in normal mode, and enters diagnostics mode when the Display button is pressed and held for 5 seconds. To adjust the contrast, hold down the Display button, and use the right and left arrow buttons to increase and decrease the contrast respectively.

### Normal Mode

In Normal mode, the Display button scrolls through the information for each meter. The left and right arrow buttons select the previous or next meter points respectively. The following information is available:

- Real Energy Delivered kWh D
- Real Energy Received kWh R
- Real Power Watts
- Reactive Energy Delivered KVarhD
- Reactive Energy Received KVarhR
- Reactive Power Var

In Normal mode, the right and left arrow buttons scroll the display from meter points 1 to 2, 1 to 3, or 1 to 6, depending on your configuration.

### Diagnostics Mode

Diagnostics mode is accessed by pressing and holding the Display button for 5 seconds. In Diagnostics mode, pressing the Display button will scroll through the following additional information:

- Send data command
- CT Primary value and Real Power Watts per phase
- Voltage per phase
- Local IP address
- Reset factory default IP address command
- Date and time (UTC)

In Diagnostics mode, the right and left arrow buttons scroll the display from meter 1 through N. When the local IP address is shown on the LCD, use the right and left arrow buttons to scroll through the following information:

- Remote host server IP address
- Time server IP address
- Default IP address
- Default NetMask
- Default gateway
- PPP user name
- Phone number
- AT command string
- Alternate phone number
- Unit serial number
- Firmware build number
- Ethernet port MAC address
- Firmware revision
- Potential transformer ratio

### **Completing the Installation Record**

The final step in the installation process is to complete the Installation Record, and record the mapping of the meters to the wired points. A copy of Figure 15, which is organised to resemble a breaker panel, is provided with each PowerHawk meter, and is to be completed and delivered to your system administrator.

Figure 15: Installation Record (sample shown)

**PowerHawk 6203 and 6303 Installation Record**



Triacta Power Technologies Inc.  
Box 582 - 7 Mill Street  
Almonte, ON Canada K0A 1A0  
Ph: (613) 256-2868  
Fax: (613) 256-6602  
www.TRIACTAPOWERTM.com

Panel Description: \_\_\_\_\_  
Customer: \_\_\_\_\_  
Address: \_\_\_\_\_  
City: \_\_\_\_\_  
Prov/State: \_\_\_\_\_  
Postal/Zip Code: \_\_\_\_\_  
Inspection Date: \_\_\_\_\_  
Inspector: \_\_\_\_\_  
PowerHawk MAC: \_\_\_\_\_ PowerHawk Serial #: \_\_\_\_\_

| Installation |  |      |  |    |  |       |  |      |  |         |   |
|--------------|--|------|--|----|--|-------|--|------|--|---------|---|
| Volts        |  | Amps |  | Hz |  | Phase |  | Wire |  | Service | Y |

| Units |       |         |          |      |       |      |       |    |       |      |          |        |
|-------|-------|---------|----------|------|-------|------|-------|----|-------|------|----------|--------|
| Insp# | Maker | Badge # | Serial # | Type | Volts | Amps | Multi | Kh | Phase | Wire | Elements | Sealed |
|       |       |         |          |      |       |      |       |    |       |      |          |        |
|       |       |         |          |      |       |      |       |    |       |      |          |        |

| PTs   |       |          |          |          |      |         |           |          |
|-------|-------|----------|----------|----------|------|---------|-----------|----------|
| Meter | Maker | Serial#A | Serial#B | Serial#C | Type | Primary | Secondary | PT Ratio |
|       |       |          |          |          |      |         |           |          |
|       |       |          |          |          |      |         |           |          |

Note: Connect the X1 lead (positive Lead) of the CT to the first colour of each wire pair (X1 CT input)

| Meter Pt # | CT | Breaker Description | circuit | phase | circuit | Breaker Description | CT | Meter Pt # |
|------------|----|---------------------|---------|-------|---------|---------------------|----|------------|
|            |    |                     | 1       |       | 2       |                     |    |            |
|            |    |                     | 3       |       | 4       |                     |    |            |
|            |    |                     | 5       |       | 6       |                     |    |            |
|            |    |                     | 7       |       | 8       |                     |    |            |
|            |    |                     | 9       |       | 10      |                     |    |            |
|            |    |                     | 11      |       | 12      |                     |    |            |
|            |    |                     | 13      |       | 14      |                     |    |            |
|            |    |                     | 15      |       | 16      |                     |    |            |
|            |    |                     | 17      |       | 18      |                     |    |            |
|            |    |                     | 19      |       | 20      |                     |    |            |
|            |    |                     | 21      |       | 22      |                     |    |            |
|            |    |                     | 23      |       | 24      |                     |    |            |
|            |    |                     | 25      |       | 26      |                     |    |            |
|            |    |                     | 27      |       | 28      |                     |    |            |
|            |    |                     | 29      |       | 30      |                     |    |            |
|            |    |                     | 31      |       | 32      |                     |    |            |
|            |    |                     | 33      |       | 34      |                     |    |            |
|            |    |                     | 35      |       | 36      |                     |    |            |
|            |    |                     | 37      |       | 38      |                     |    |            |
|            |    |                     | 39      |       | 40      |                     |    |            |
|            |    |                     | 41      |       | 42      |                     |    |            |
|            |    |                     | 43      |       | 44      |                     |    |            |
|            |    |                     | 45      |       | 46      |                     |    |            |
|            |    |                     | 47      |       | 48      |                     |    |            |
|            |    |                     | 49      |       | 50      |                     |    |            |
|            |    |                     | 51      |       | 52      |                     |    |            |
|            |    |                     | 53      |       | 54      |                     |    |            |
|            |    |                     | 55      |       | 56      |                     |    |            |
|            |    |                     | 57      |       | 58      |                     |    |            |
|            |    |                     | 59      |       | 60      |                     |    |            |

## MAINTENANCE

Do not perform any operation or maintenance procedures that are not described in this product documentation. No preventive maintenance is required on any of the equipment. Visually inspect the equipment yearly and ensure it is free of dust or other particles. If necessary, wipe with a clean cloth. Individual components are not user-serviceable and must be returned to Triacta Power for repair.

### Fuse Replacement

| <b>⚠ DANGER</b>  |  |
|--|--|
| <b>HAZARD OF ELECTRIC SHOCK, EXPLOSION, OR ARC FLASH</b>   |  |
| <ul style="list-style-type: none"><li>• Apply appropriate personal protective equipment (PPE) and follow safe electrical work practices. See NFPA 70E.</li><li>• Turn off all power supplying this equipment before working on or inside equipment.</li><li>• Always use a properly rated voltage sensing device to confirm the power is off.</li><li>• Replace all devices, doors and covers before turning on power to this equipment.</li></ul> |  |
| <b>Failure to follow these instructions will result in death or serious injury.</b>  |  |

1. Turn off all sources of power before attempting to replace the fuse. Always use a properly rated voltage sensing device to confirm the power is off.
2. Remove the outer cover from the unit.
3. Locate fuse F1 at the top left corner inside the unit.
4. Remove the fuse cover, then remove the fuse from the holder as shown in Figure 16.
5. Replace fuse F1 with a fuse that meets the specifications listed in Table 1 on page 2.
6. Replace the fuse cover.
7. Re-install the cover and turn on the power source.

**Figure 16: Replacing the fuse**

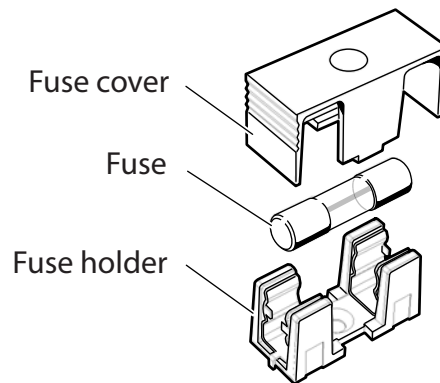

## REGULATORY COMPLIANCE

The PowerHawk meter must be installed by a certified electrician with knowledge of local safety regulations. Initial installation of the unit, and any subsequent modification to the unit, must be inspected by the local electrical safety authority.

The PowerHawk meter complies with the standards listed in Table 3.

**Table 3: Regulatory Compliance**

| Discipline                  | Regulatory and industry standard  |
|-----------------------------|---|
| Safety                      | UL certified to IEC/EA/UL/CSA 61010-1 2 <sup>nd</sup> Edition<br>CSA-C22.2 No. 61010-1-04 |
| Emissions (EMC)             | FCC Part 15 Class B, ICES-003 EN55022, IEC 6100-4-5                                       |
| Surge power/telephone lines | ANSI/TIA968-A: 2002   |

## Equipment servicing and access

The information in this section must be considered as a mandatory requirement, and must be strictly adhered to when installing and operating PowerHawk 6203 and 6303 meters.

### Access to equipment

The equipment must be accessible to authorized personnel only. Equipment must be installed in areas where access can be restricted.

### Servicing the equipment

No preventive maintenance is required on any of the equipment. Visually inspect the equipment yearly and ensure it is free of dust or other particles. If necessary, wipe with a clean cloth.

### Component servicing



Individual components are not user-serviceable, and must be returned to Triacta Power for repair. If an equipment fault occurs, do not attempt to repair the faulty component.

All maintenance activities should be performed by qualified personnel only. Do not perform any operating or maintenance procedures that are not described in the product documentation provided by Triacta Power.

**Graphical symbols**

Table 4 shows the graphical symbols that appear on the equipment.

**Table 4: Graphical symbols that appear on equipment**

| Symbol  | Description   |
|---|---|
|  | Indicates the supply wire protective earth, also known as chassis ground, for the primary ground. |
|  | This symbol indicates a replaceable fuse.   |



## Index

### Numerics

- 347V installation
  - typical three-phase configuration 11
- 5A converters and current transformers
  - install 22

### A

- audience 1

### C

- compliance
  - electrical safety 5
- control voltage and current
  - meter 2
- current transformers
  - install 21
  - meter 2

### D

- delta service
  - install sense voltage and control voltage cables 12
- dimensions
  - meter 2

### E

- electrical safety compliance 5
- equipment
  - access 30
  - servicing 30
- equipment servicing 30

### F

- fuse rating
  - meter 2

### I

- install
  - 5A converters and current transformers 22
  - potential transformers 10
- installation 6
- installation procedures
  - overview 7
- Installing 22

### M

- maximum altitude
  - meter 2
- maximum pulse per second
  - meter 2
- measurement accuracy
  - meter 2
- meter
  - control voltage and current 2
  - CT color pair identification 23
  - current transformers 2
  - dimensions 2
  - fuse rating 2

- installation in a 120/208V three-phase wye panel with 120V variant 15
- installation in a 240/416V three-phase wye panel with 230/240V variant 16
- installation in a 277/480V three-phase wye panel with 120V variant 17
- installation in a 347/600V or higher three-phase wye panel with 120V variant 18
- installation in a single-phase panel with 120V variant 14
- installation in a three-phase Delta panel with 120V variant 19
- internal view 4
- maximum altitude 2
- maximum pulse per second 2
- measurement accuracy 2
- minimum pulse width 2
- mounting 8
- NVM storage 2
- onboard Ethernet port 2
- onboard modem 2
- operating humidity 2
- operating temperature 2
- pollution degree 2
- pulse inputs 1 and 2 2
- sense voltage 2
- serial port 2
- specifications 2
- usage environment 2
- weight 2
- meter map
  - recording 27
- minimum pulse width
  - meter 2
- mounting
  - meter 8

### N

- NVM storage
  - meter 2

### O

- onboard Ethernet port
  - meter 2
- onboard modem
  - meter 2
- operating humidity
  - meter 2
- operating temperature
  - meter 2

### P

- pollution degree
  - meter 2
- potential transformers
  - install 10
- pre-installation 6
- pulse inputs 26

pulse inputs 1 and 2  
meter 2

## **S**

sense voltage  
meter 2  
sense voltage and control voltage cable installation  
wye and delta service 12  
serial port  
meter 2  
servicing equipment 30  
site planning 6  
site preparation  
lighting 7  
power 7  
specifications  
meter 2  
start-up sequence 25

## **U**

usage environment  
meter 2

## **W**

weight  
meter 2  
wye service  
install sense voltage and control voltage cables 12

## USER NOTES





**PowerHawk 6312 and 6412 meters  
Installation Guide**

**Triacta Power Technologies Inc.**  
7 Mill Street  
Almonte, Ontario  
K0A 1X0  
[www.triacta.com](http://www.triacta.com)

Electrical equipment should be installed, operated, serviced, and maintained only by qualified personnel. No responsibility is assumed by Triacta Power for any consequences arising out of the use of this material.

930-119-01-B.00 © 2011 Triacta Power Technologies All Rights Reserved